

# Investigation on Voltage Stability of Dynamic Power System

*R.Karthikeyan*

---

## ABSTRACT

In this paper the voltage stability of a power system is analyzed using Hopf bifurcation. Voltage stability analysis of a power system is necessary during the planning and operation stages of the power system. In today's scenario where the power system is almost operated at the stability margin, analysis of the voltage stability is obligatory. Bifurcation theory which holds good for Voltage stability analysis has been applied to the IEEE 14 test bus system with dynamic components. The Continuation Power Flow (CPF) and Eigen value analysis was carried out. The presence of Eigen values with negative complex conjugate values indicates the presence of Oscillatory instability. The study was carried out using PSAT tool box.

---

Keywords: Continuation Power Flow (CPF), Eigen value analysis, Hopf Bifurcation, PSAT, Saddle Node Bifurcation.

---

## 1. Introduction

The power systems are the world's largest and most complex nonlinear systems. The power system includes a large number of equipment's which interact with each other and thus exhibiting nonlinear dynamics with a wide range of time frame. When the power system is subjected to a disturbance, the stability of the power system will depend on the initial operating condition as well as the nature of the disturbance. For a wide varieties of reasons many power systems in real time are operated near to their stability limits and thus they become more vulnerable to losing the voltage stability. When these limits are exceeded, the system can exhibit undesired responses with the voltage profile reaching undesired values. This indicates the presence of voltage instability phenomenon.

Voltage instability is basically a nonlinear phenomenon and it is natural to use nonlinear analysis techniques such as bifurcation theory to study voltage instability and to devise ways of mitigating it. Voltage stability problems in power systems may occur for a variety of reasons, from voltage control problems with Automatic Voltage Regulators (AVR) and Under-Load Tap-Changer(ULTC) transformers, to instabilities created by different types of bifurcations. Bifurcations, or turning points, have been recognized as some of the reasons, albeit not the only ones, for voltage stability problems in a variety of power system models. As certain parameters in the system change slowly, allowing the system to recover quickly and maintain a stable operating point, the system eventually turns unstable, either due to one of the Eigen values becoming zero (saddle-node, transcritical, pitchfork bifurcations), or due to a pair of complex Eigen values crossing the imaginary axis of the complex plane (Hopf bifurcation). The instability of the system is reflected on the state variables, usually represented by frequency, angles and voltages, by an oscillatory behavior.

Local bifurcations are detected by monitoring the Eigen values of the current operating point. The stability of a linear system can be determined by studying Eigen values of the state matrix as follows. The system is stable if all real parts of Eigen values are negative. If any real part is positive the system is unstable. For the real part is zero we cannot say anything.

## 2. Small Disturbance Analysis Method

The dynamic characteristic of a high order power system can be described by a parameter depending differential algebraic equation shown in (1) and (2)

$$\dot{X} = f(X, Y, p) \quad (1)$$

$$0 = g(X, Y, p) \quad (2)$$

where equation (1) represents the dynamic characteristic of the system components such as generators, exciter systems, load and other control systems. Equation (2) is the load flow equations. X represents the system state variables such as generator voltages ( $E'$ ,  $E'_q$ ,  $E''_q$ ), rotor variables ( $\omega$ ,  $\delta$ ) excitation voltage  $E_{fd}$ , speed governor variables, etc. Y in the equation 3 represents the algebraic variables such as magnitudes and angles of bus voltages. p is the system load power parameter. Given parameter p, the system equilibrium point X' is the solution of the following equation.

$$\begin{pmatrix} F(X', Y, p) \\ G(X', Y, p) \end{pmatrix} = 0 \quad (3)$$

The system stability at equilibrium point X' can be identified by solving the linearised (1) and (2) at the equilibrium point

$$\begin{bmatrix} \Delta \dot{x} \\ \Delta y \end{bmatrix} = J \begin{bmatrix} \Delta x \\ \Delta y \end{bmatrix} \quad J = \begin{bmatrix} f_x & f_y \\ g_x & g_y \end{bmatrix} \quad (4)$$

Assuming that  $g_y$  is non singular, it is able to eliminate  $\Delta y$  from (4). As a result, the following equation is obtained.

$$\Delta \dot{X} = A \Delta X \quad (5)$$

$$A = f_x - f_g g_y^{-1} g_x \quad (6)$$

From (6), it is easy to analytically evaluate the stability by the state matrix A, which is often called the reduced Jacobin matrix compared with the unreduced one J. With the state matrix A, the system stability can be evaluated by the Eigen value analysis method, which is one of the stability analyzing method belonging to the Lyapunov stability theory. The main advantage of this method is that the dynamic characteristics of the generator, the excitation system, as well as the load are all included.

When the system parameters and/or p (such as load of the system) vary, the stable equilibrium points may lose its dynamic stability at local bifurcation points. As the parameters change, the Eigen values associated with the corresponding those equilibrium point will tend to change as well. The variation in the system parameter results may result in local bifurcation. The analysis of equilibrium of the Differential Algebraic Equation (DAE) model often results in three major bifurcations, Saddle Node Bifurcation (SNB), Hopf Bifurcation and Singularity Induced (SI) bifurcations.

A saddle-node bifurcation is basically a local phenomenon and it is the disappearance of a system equilibrium as parameters change slowly. The saddle-node bifurcation are of most interest to power system engineers occurs when a stable equilibrium at which the power system operates disappears due to the merger of Stable equilibrium point and the unstable equilibrium point. The point where a complex conjugate pair of Eigen values reach the imaginary axis with respect to the changes in ( $\lambda$ , p), say ( $x_0$ ,  $y_0$ ,  $p_0$ ,  $\lambda_0$ ), is known as a Hopf bifurcation point.

The Eigen value analysis is used to identify various types of bifurcation. When all the Eigen values of the state matrix have negative real part, the system is stable; when there is zero Eigen values or pure imaginary Eigen values, the system reach the stability critical point; when Eigen values with positive real part emerge, the system will loss the stability.

Flexible AC transmission system is Alternating current transmission systems incorporating power electronics based and other static controllers to enhance controllability and power transfer capability. The Static Var Compensator (SVC) is a shunt device of the Flexible AC Transmission Systems (FACTS) family using power electronics to control power flow and improve transient stability on power grids. The SVC regulates voltage at its terminals by controlling the amount of reactive power injected into or absorbed from the power system. When system voltage is low, the SVC generates reactive power (SVC capacitive). When system voltage is high, it absorb reactive power (SVC inductive). The variation of reactive power is performed by switching three-phase capacitor banks and inductor banks connected on the secondary side of a coupling transformer. Each capacitor bank is switched on and off by three thyristor switches (Thyristor Switched Capacitor or TSC). Reactors are either switched on-off (Thyristor Switched Reactor or TSR) or phase-controlled (Thyristor Controlled Reactor or TCR). A rapidly operating Static Var Compensator (SVC) can continuously provide the reactive power required to control dynamic voltage swings under various system conditions and thereby improve the power system transmission and distribution performance. Installing an SVC at one or more suitable points in the network will increase transfer capability through enhanced voltage stability, while maintaining a smooth voltage profile under different network conditions. In addition, an SVC can mitigate active power oscillations through voltage amplitude modulation

PSAT includes power flow, continuation power flow, optimal power flow, small-signal stability analysis, and time-domain simulation. The toolbox is also provided with a complete graphical interface and a Simulink-based one-line network editor. The features that are present in the PSAT includes the power flow (PF), the continuation power flow and/or voltage stability analysis (CPF-VS), the optimal power flow (OPF), the small-signal stability analysis (SSA), and the time-domain simulation (TD), along with "aesthetic" features such as the graphical user interface (GUI) and the graphical network editor (GNE).

### 3. Simulations and Result Analysis

To investigate the voltage stability problems encountered due to the existence of bifurcation, and to select appropriate control equipment's the IEEE14 bus dynamic model was chosen.

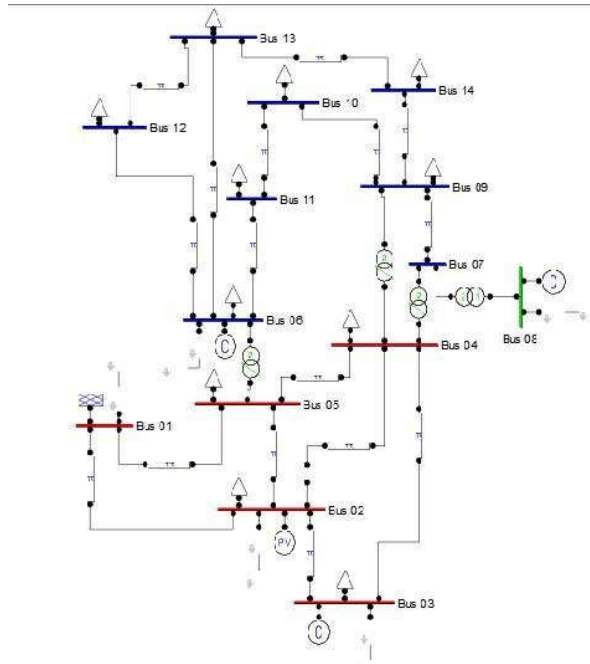

**Figure 1:** Dynamic IEEE 14 BUS TEST SYSTEM

Initial power flow was run using Newton Raphson algorithm. The Continuation Power Flow program was executed using Power System Analysis Tool Box (PSAT). From the analysis of the power flow results it was observed that bus 14 was the weakest bus. The CPF was executed with bifurcation point as the stopping criteria. From the CPF it was determined that the voltage stability margin is 1.7188 pu.

Then the Eigen Analysis was carried out. The test results revealed the occurrence of the Hops bifurcation at 0.727 loading. The maximum loading limit is 1.7188 where the Jacobian matrix becomes singular. The Eigen value analysis plot is depicted in the figure.

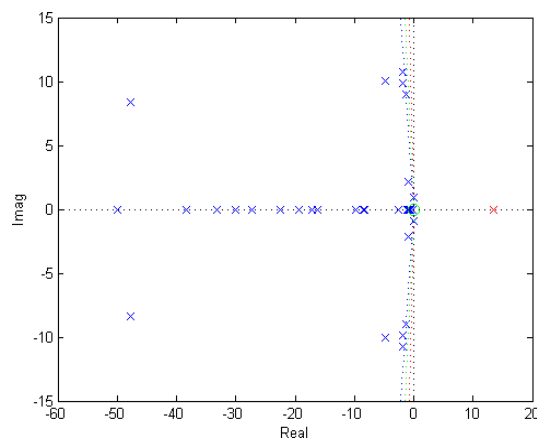

**Figure 2:** Eigen value plot of IEEE 14 Test Bus System

The closer analysis of the Eigen values shows the existence of an Eigen value with zero, indicating the existence of Saddle Node Bifurcation. The presence of a seven complex conjugate pair indicates the occurrence of Hops bifurcation. The table also shows the most associated states and their corresponding participating factor values and their frequencies. Mode 31 and mode 32 have the least real part indicating that they are the one which if uncontrolled will end up in crossing the real axis and thus ending up in Oscillations.

**Table 1:** Complex Eigen Value Pairs

Modes	EIGEN VALUES
Eig -6,7	-47.6508 ±j 8.3511
Eig -18,19	-4.7071±j 10.0182
Eig -20,21	-1.7939±j 10.7604
Eig-22,23	-1.8848±j 9.9033
Eig-24,25	-1.3202±j 8.9543
Eig-29,30	-0.84671±j 2.1375
Eig-31,32	-0.07829±j 0.88442

To improve the stability of the system ,SVC was introduced at bus number 14 and the CPF ,Eigen analysis was carried out. The Eigen value analysis shows that the positive and zero Eigen values has disappeared indicating the stability of the system has increased.

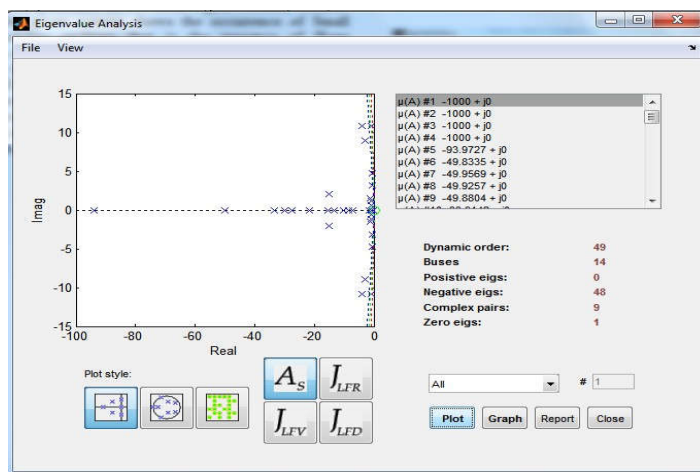
**Figure 3:** Eigen value plot of IEEE 14 Test Bus System with Compensation

#### 4. Conclusion

This paper investigates the dynamic voltage stability of a Dynamic IEEE14 test bus system. The simulation was carried out using CPF and Eigen value analysis which reveals the presence of complex conjugate pairs of Eigen values along with the presence of one Eigen value with zero, which is a clear indication about the existence of Hops bifurcation and Saddle Node bifurcation which lead the system to voltage instability. The analysis also shows that the introduction of SVC in the appropriate bus, significantly improves the Voltage stability of the system.

#### REFERENCES

- [1] Abed, E. H., Wang, H. O., Alexander, J. C., Hamdan, A. M. A., Lee, H. C.(1993) Dynamic bifurcations in a power system model exhibiting voltage collapse.Int. J. of Bifur. Chaos, 3:1169–1176.
- [2] C. A. Cdeares, F. L. Alvarado, C. L. DeMarco, I. Dobson, W. F. Long, “Point of Collapse Methods Applied to AC/DC Power Systems,” IEEE Trans. Power Systems, Vol. 7, No. 2, May 1992, pp. 673-683.
- [3] R.Govindarajan, S.Meikandasivam and D.Vijayakumar “Performance Analysis of Smart Energy Monitoring Systems in Real-time,” Engineering, Technology & Applied Science Research, vol. 10, no. 3, pp. 5808–5813, Jun. 2020.
- [4] Ajjarapu and B. Lee, “Bifurcation Theory and its Appli-cation to NoilinearDynamical Phenomena in an Electrical Power System,” IEEE Trns. Power Systems, Vol. 7, Febru- ary1992, pp. 424-431.
- [5] D.J. Hill and I.M.Y. Mareels, “Stability theory for Differential/Algebraic systems with application to power systems,” *IEEE Trans. Circuits and Systems*, vol. 37, no. 11, pp. 1416-1423. Nov. 1990.
- [6] Akhmatov and H. Knudsen, “An aggregate model of a grid-connected,large scale, offshore wind farm for power stability investigations-Importance of windmill mechanical system,” *Int. J. Elect. PowerEnergy Syst.*, vol. 24, pp. 709--717, Nov. 2002.

- [7] F. Zhou, G. Joos, and C. Abbey, "Voltage stability in weak connection wind farms," in *Power Engineering Society General Meeting*, San Francisco, vol. 2, pp. 1483--1488, Jun. 2005.
- [8] Abed, E. H., Varaiya, P. P. (1984) Nonlinear oscillations in power system. *Int. J. of Electr. Power Energy Syst.*, 6:37-43.
- [9] R. Govindarajan, S. Meikandasivam, D. Vijayakumar, "Low cost Arduino based smart energy monitoring system using internet of things", *Journal of Engineering and Applied Sciences*, Vol. 14, No. 1, pp. 170- 177, 2019.
- [10] Ajarapu, V. A., Lee, B. (1992) The continuation power flow: A tool for steady state voltage stability analysis. *IEEE Trans. Power Syst.*, 7:416-423.
- [11] Ajarapu, V. A., Lee, B. (1992) Bifurcation theory and its application to nonlinear dynamical phenomena in an electric power system. *IEEE Trans. Power Syst.*, 7:424-431.
- [12] Budd, C. J., Wilson, J. P. (2002) Bogdanov-Takens bifurcation points and Sil'nikov homoclinicity in a simple power-system model of voltage collapse. *IEEE Trans. Circ. Syst.-I*, 49:575-590.
- [13] Abed, E. H., Wang, H. O., Alexander, J. C., Hamdan, A. M. A., Lee, H. C. (1993) Dynamic bifurcations in a power system model exhibiting voltage collapse. *Int. J. of Bifur. Chaos*, 3:1169-1176.
- [14] Abed, E. H., Varaiya, P. P. (1984) Nonlinear oscillations in power system. *Int. J. of Electr. Power Energy Syst.*, 6:37-43
- [15] Ajarapu, V. A., Lee, B. (1992) The continuation power flow: A tool for steady state voltage stability analysis. *IEEE Trans. Power Syst.*, 7:416-423
- [16] R. Govindarajan, S. Meikandasivam, D. Vijayakumar, "Energy monitoring system using Zigbee and Arduino", *International Journal of Engineering & Technology*, Vol. 7, No. 4, pp. 608-611, 2018.
- [17] Ajarapu, V. A., Lee, B. (1992) Bifurcation theory and its application to nonlinear dynamical phenomena in an electric power system. *IEEE Trans. Power Syst.*, 7:424-431.
- [18] Budd, C. J., Wilson, J. P. (2002) Bogdanov-Takens bifurcation points and Sil'nikov homoclinicity in a simple power-system model of voltage collapse. *IEEE Trans.*