

ASRS Guided Vehicle based on Inventory Management Using Smart IOT

S. S. Saravana Kumar

ABSTRACT

The global increases in consumption of products such as automobiles and electronics have been pushing for more efficient and faster production facilities. This trend has given rise to technologies specifically for automation of production lines and inventory allocation. The problem however is that many of the job practices such as stock taking upon delivery and supplies to assembly lines cannot be easily automated. Thus we aim to partially automate the management of inventories and storage and retrieval of materials from assembly stations using a combination of automated guided vehicle and IoT technology.

Keywords: ASRS, IOT, AGV, LiDAR, Autonomous Mobile Robot, Blynk.

1. Introduction

The exponential increase in population size is not only demanding more from already strained production of natural resources but also on processed goods which are more often than not mass-produced. This demand has pushed production facilities towards smarter and more efficient manufacturing techniques but also the partial and occasionally full automation of their production line. The problem conversely is that no matter how efficient the production line its production will be mainly based how fast and efficiently the raw materials and produced goods are moved to and from the production lines as well as how they are accounted for. This project thus aims to address these issues by designing a system that increases the delivery and retrieval of goods from and to the production line and tracks the usage and production of materials in real-time using technologies such as Wifi guided vehicle and Internet of Things. The retrieval of goods to and from the production lines are currently done either manually and with the aid of a human-controlled machine such as forklifts and delivery carts using a variety of optimization techniques such as JIT (Just-In-Time) manufacturing system (Toyota Production System), On-Demand-Manufacturing or the partial/full automation of production lines. The inventory management systems have been fully automated as of present but these systems are mainly used for warehousing models and not in production facilities. Examples of such systems include Amazon Smart Warehousing and JDI's fully automated warehouse amongst others.

JIT (Just-In-Time) system has been developed by Taiichi Ohno (1982), Executive Vice-President of the Toyota Motor Company and it spread to other companies of Japan in the late 1970s. JIT or Just-in-Time manufacturing is the minimization of labour, production time and raw materials by only producing goods as they are demanded. It is the concept of delivering raw materials and producing products when there is a need. The main focus of this optimization technique is on minimizing the raw material use, work-in-process, and finished goods inventory with a focus on cutting inventory costs whilst helping to expose other more serious inefficiencies (such as poor maintenance, inspection, backlogs, etc.) in the manufacturing cycle. [1]. The other part in optimization a maximization of manufacturing is achieved through the automating of inventory system and production lines. Here is a more detailed look at these technologies solution providers. An on-demand automation solution works right out of the box. Where cloud-based platform means no on-premises server installation, no dedicated Wi-Fi, and no software to install. The Warehouse Management System (WMS) integration is not required for operation but can easily be implemented through our API's and SDKs as needed. [2]. With on-demand automation, robots can be easily re-purposed by the user with a simple-to-use, intuitive interface. These solutions can adapt and operate to a variety of warehouse environments, including logistics,

distribution, e-commerce, retail, and manufacturing. It is not limited to a single-function workflow, as with traditional automation or specialized AMRs. Fetch Robotics provides the market's only cloud-driven Autonomous Mobile Robot (AMR) solution that addresses material handling and data collection for warehousing and intralogistics environments. Fetch Robotics' AMRs reduce costs and improve throughput, efficiency, and productivity while working alongside people. The Fetch Cloud Robotics Platform provides the only Autonomous Mobile Robot (AMR) solution that deploys in hours vs. Days or weeks and addresses multiple applications – including material handling and data collection - with a common, unified, cloud-based platform. We offer turnkey and extensible systems that safely find, track, and move anything from parts to pallets in warehouses, factories, and distribution centers.

In the era of e-commerce, the logistic distribution centre is put in the central role of order picking for the sake of meeting the needs of different customer orders, hence, improving the automation and work capacity of distribution centre becomes research priority in the fields of logistics and warehousing. The Amazon's Kiva system, that is, mobile racking with goods is broke out to sorting table by Kiva mobile robots named AGVs (Automated guided vehicles), which could not only reduce the walk time and labour cost, but improve efficiency, which triumph over the currently traditional distribution centre picking system with high automation. [3]. The AGVs operate on set paths and re-organise the shelves of a warehouse to improve the ease of storing and retrieving of goods. The robots use a combination of LiDAR technology and Artificial intelligence to navigate themselves and their loads around a warehouse.

The load capacity of the AGVs is variable between 500 to 1300 kilograms due to their limited size of just several feet.

Although current technological solutions have advanced far from what they once were they are not without their drawbacks. The major drawback of these systems is that they are mostly if not always configured towards a station environment, that they are geared towards only the warehousing part of the manufacturing and not the production field itself. This is mainly due to factors such as, Limited floor space in production fields (compared to warehousing), Need for the inclusion of variable supply and demands of goods to accommodate varying production rates, Employees dispute issue with regards to the inclusion of robots into work environments, High initial implementation costs, Need for sophisticated and high-end technologies such as Artificial intelligence and LiDAR-based mapping., The entire systems only offer partial automation and not true automation, that the systems still human correction on, before or after the robot has completed its job. Some of the individual examples mentioned in the literature survey do offer solutions to the above mention issue but these solutions as best only solve the problems partially and not fully as one would expect.

2. System Model

As mentioned previously even the most advanced of current day's technological solutions and optimization methods do not offer the best manufacturing efficiency since they do not focus on the entire process but rather the optimization of a specific portion of manufacturing. There is also the issue of the systems complexity and pricing that is as the complexity of the given solution/system increases so does its price. Thus the proposed main aim is to integrally increase the working efficiency of all aspects of the manufacturing process. These issues have all been addressed in our project which uses a concept of a smart ASRS system which operates (storing and retrieval of materials) using a simple AGV (Automated Guided Vehicle) that shuttles goods between the production lines and storage facilities all whilst automatically updating the stock inventory in real-time using IoT technology.

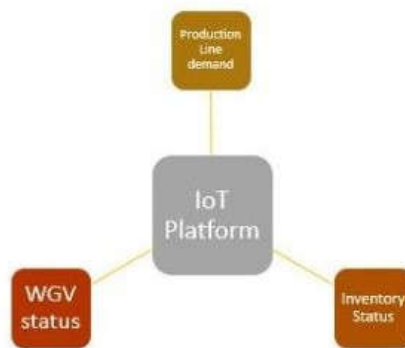

Fig. 1 - Block diagram of working of proposed system

The working of the proposed model hinges on mainly four factors, IoT Cloud platform, Status of Automated Guided Vehicle, Inventory status, tracking of production line demand. This system ensures the optimization of manufacturing holistically by integrating the storage, supply and production lines. Thus the core components of this system can be divided into three parts, WGV, IoT integrated production and storage facilities, IoT Cloud Platform. The concept of this proposed solution is further visualized in the project and a scaled prototype model which will emulate the working of a full-scale deployment or for further research and optimization

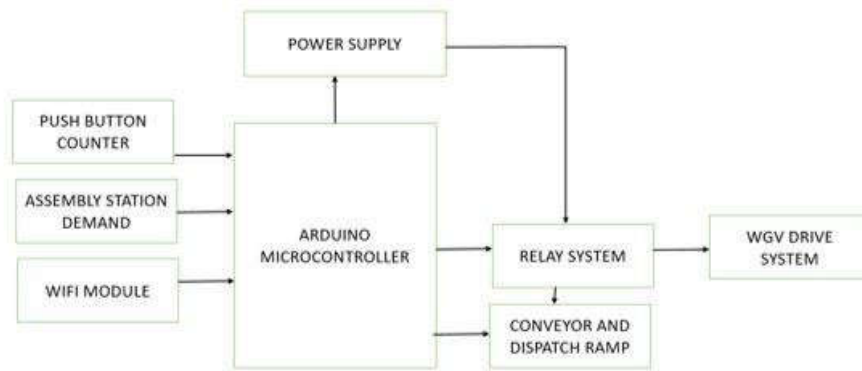

Fig. 2 – System Block Diagram

NodeMCU is a low-cost open source IoT platform. It initially included firmware which runs on the ESP8266 Wi-Fi SoC from Espressif Systems, and hardware which was based on the ESP-12 module. Later, support for the ESP32 32-bit MCU was added. NodeMCU is an open source firmware for which open source prototyping board designs are available. The name "NodeMCU" combines "node" and "MCU" (micro-controller unit). The term "NodeMCU" strictly speaking refers to the firmware rather than the associated development kits. Motor Driver – L293D Driver Module is a medium power motor driver perfect for driving DC Motors and Stepper Motors. It uses the popular L293 motor driver IC. It can drive 4 DC motors on and off, or drive 2 DC motors with directional and speed control. The driver greatly simplifies and increases the ease with which you may control motors, relays, etc from micro-controllers. It can drive motors up to 12V with a total DC current of up to 600mA. The DC motors runs at 100 rpm at 12v and which in turn controls the wheels of the AGV. It is a simple DC motor featuring metal gearbox for driving the shaft of the motor, so it is a mechanically commutated electric motor which is powered from DC supply. Wheels which are compactable with the DC motor is connected to the shaft of the DC motors. Clamps are attached to the frame of the AGV which helps for good movement of the robot.

Blynk is a new platform that allows you to quickly build interfaces for controlling and monitoring your hardware projects from your iOS and Android device. After downloading the Blynk app, you can create a project dashboard and arrange buttons, sliders, graphs, and other widgets onto the screen. Using the widgets, you can turn pins on and off or display data from sensors. WiFi Guided vehicle is controlled by a set of keys which is created manually in the blynk application in our device. The communication between the vehicle and blynk application is through the Wi-Fi medium. The each keys have a separate commands such as moving forward, backward etc. There are four keys created in the blynk application for the respective directions. The program specifies the direction for each keys. The Arduino Mega 2560 is a microcontroller board based on the ATmega2560. It has 54 digital input/output pins (of which 15 can be used as PWM outputs), 16 analogue inputs, 4 UARTs (hardware serial ports), a 16 MHz crystal oscillator, a USB connection, a power jack, an ICSP header, and a reset button. It contains everything needed to support the microcontroller; simply connect it to a computer with a USB cable or power it with an AC-to-DC adapter or battery to get started.[7]. Ultrasonic sensors emit short, high-frequency sound pulses at regular intervals. If they strike an object, then they are reflected as echo signals to the sensor, which itself computes the distance to the target based on the time-span between emitting the signal and receiving the echo. Ultrasonic sensors are used to have a count of the stock that is stacked in the inventory system. Another ultrasonic sensor is placed to count the number of finished product that is stored from the stations. We use two ultrasonic sensors in our system.

When the IR transmitter transmits light waves onto to the reflective surface the waves bounce back and are received by the IR receiver which is placed close to the transmitter. If the Receiver successfully receives the signal (i.e. the light waves were not absorbed by the black lined track) it will send a high signal to the motor driver to control the given motor. An IR sensor is placed to detect the arrival of the WGV. Once the WGV is detected the signal is sent to the Arduino.[6]. The Arduino gives the command to the motor to dispatch the materials onto the WGV. This is done only when the IR sends the signal to the Arduino. The motor has an arm attached to its shaft. The motor is setup in such a way that it pushes the materials onto WGV through the ramp attached to the inventory. The inventory data is updated to the cloud for easy management of the stock available and also the amount of number of finished products. This is achieved using the esp 8266 wifi module which updates the data to the cloud. The stock or the amount of materials available is calculated using the ultrasonic sensor which is placed in both the inventory and finished products storage station. The ultrasonic sensor data is updated to the cloud with the help of Arduino and through the esp 8266 wifi module. The whole system works based on the demand in the production line. Once the demand is indicated the WGV gets the required components from the inventory and dispenses it to the respective stations and also it collects the finished products from the stations and dispenses it to the finished product storage unit.

3. Conclusion

Thus the prototype of Wi-Fi Guided Vehicle has been built and tested successfully. Presence of every module has been reasoned out and placed carefully, thus contributing to the best working of the WGV whilst meeting all the set requirements set due to the issues with current technologies and doing so within it given parameters of low-cost high productivity. Further our work will be helpful in future, As a world move towards smarter and faster production and production facilities we often forget that these cutting edge solutions are or may not be the most viable solution for the majority of the populace that is although current technologies do offer very efficient and speedy productions they are not always adopted due to constraints such as

production facility size and economic feasibility. Thus our proposed model of using a simplified automated guided vehicle which in conjunction with IoT cloud technologies has the potential to be largely successful as its main focus lies in improving production efficiency whilst decreasing economic strains and need for skilled labour (maintenance of complex systems) as much as possible. This system can be further improved when technologies such as LIDAR mapping systems and 5G networking become more financially and commercially feasible.

REFERENCES

- [1] Singh, G. and Ahuja, I.S. (2012) 'Just-in-time manufacturing: literature review and directions', *Int. J. Business Continuity and Risk Management*, Vol. 3, No. 1, pp.57–98.
- [2] Fetch robotics. 2018. WHAT IS ON-DEMAND AUTOMATION. [Online]. [1 November 2019]. Available from: <https://fetchrobotics.com/what-is-on-demand-automation/>
- [3] Jun-tao Li, Hong-jian Liu. Design Optimization of Amazon Robotics. *Automation, Control and Intelligent Systems*. Vol. 4, No. 2, 2016, pp. 48-52. DOI: 10.11648/j.acis.20160402.17
- [4] Liang, Conghui & Chee, K.J. & Zou, Y. & Zhu, Haifei & Causo, Albert & Vidas, Stephen & Teng, T. & Chen, I-Ming & Low, K.H. & Cheah, C.C.. (2015). Automated Robot Picking System for E-Commerce Fulfillment Warehouse Application.
- [5] Khan, A. and Turowski, K. A Perspective on Industry 4.0: From Challenges to Opportunities in Production Systems. DOI: 10.5220/0005929704410448 In Proceedings of the International Conference on Internet of Things and Big Data (IoTBD 2016), pages 441–448 ISBN: 978-989-758-183-0
- [6] Pakdaman, Mehran & Sanaatiyan, Mohammad Mehdi & Rezaei, Mahdi. (2010). A line follower robot from design to implementation: Technical issues and problems. 5 - 9. 10.1109/ICCAE.2010.5451881.
- [7] Arduino. 2019. ARDUINO MEGA 2560 REV 3. [Online]. [2 November 2019]. Available from: <https://store.arduino.cc/usa/mega-2560-r3>
- [8] Arduino. 2019. Arduino. [Online]. [2 November 2019]. Available from: <https://www.arduino.cc/en/main/software>
- [9] Arduinocc. 2019. ARDUINO UNO 3. [Online]. [1 November 2019]. Available from: <https://store.arduino.cc/usa/uno>.