

Help and Saftey System in Vehicle

Abhiraj Sutar, Anshu De, Shraddha Sukale, Rushikesh Dabetwar*

ABSTRACT

In this paper, the state of the art of Steel Castellated Beams' manufacturing, applications, and its failure pattern is explained. The current research status of castellated beam activity is not mature and needs a lot to be researched in relation to beams without web openings. The presence of different opening forms such as square, hexagonal, rectan-gular, octagonal and oval etc. in the web beams introduces several additional failure modes, namely; lateral-torsional buckling of web posts, shear force web post buckling, forming of four plastic hinges around the opening corners, rupture of welded joints over traditional steel beams in the castellated beams. To ensure a effective web opening of the castellated beam optimization techniques such as tug of war algorithm, charged system algorithm in MATLAB coding or genetic algorithm are introduced in this paper. Apart from this FEM analysis of experimental and theoretical studies are mentioned considering the impact of different parameters, such as opening forms, opening distance, opening spacing, different number of openings etc.

Keywords: Castellated steel beam, Conventional beam, Lateral-torsional buckling, Vierendeel mechanism, Tug of War Algorithm, MATLAB, Genetic algorithm, FEM analysis

1. Introduction

The first, especially in the United States, refers to vehicle safety measures that help prevent accidents, such as the effective braking. In this case, safety refers to factors that help reduce the effects of the accident, such as seat belts, airbags and sturdy body structures. These uses are interchangeable in terms of the basic and secondary security measures commonly used in the UK.

However, effective safety is increasingly used to describe systems that use vehicle sensitivity to avoid and minimize the effects of an accident. This includes braking systems, such as brake assist, traction control systems and electronic stability control systems, which translate signals from various sensors to help the driver control the vehicle.

In addition, forward-facing, sensory-based systems such as pilot-assisted systems including cruise control and warning / avoidance / mitigation systems are also considered effective security systems under this definition. This forward-looking technology is expected to play a growing role in collision avoidance and reduction in the future.

Most suppliers of heavy equipment the traction control system (TCS), also known as the ASR is generally (but not really) the second function of electronic stability control (ESC) in production vehicles, designed to prevent loss of towed road wheels. TCS is effective if the input of the throttle and engine torque does not match road conditions. Intervention consists one or more than one of the following: Brake force applied to one or more wheels .Reduction or suppression of spark sequence to one or more cylinders. Reduction of fuel supply to one or more cylinders. Closing the throttle, if the vehicle is fitted with drive by wire throttle

2. Literature Review

Some Information we got regarding the project from Research papers, Articles and websites. As a fundamental concept of the automotive industry, automotive power plays an important role in the development of the automotive industry. In recent decades, there has been significant progress in the design and testing of motor vehicles. Recent developments in car flexibility. In automotive dynamics, the body of the vehicle (sprung mass), the suspension part (spring and damper) and the wheel (mass unsprung) are important parts of the system. The modelling approaches and characteristics of the vehicle, tire and driver model with the respect to handling and driving

Dynamics are summarized in the paper. The important research issues about the vehicle-pavement coupled dynamics are discussed in detail. Several problems and directions for the further studying in vehicle dynamics are pointed out. Identifying how vehicle dynamics affect operating the vehicle is essential to student safety. The primary objective is to maintain a positive contact patch between the vehicle's tires and the surface of the road.

Data acquisition is the processing of multiple electrical or electronic inputs from devices such as sensors, timers, relays, and solid-state circuits for the purpose of monitoring, analysing and/or controlling systems and processes. Data acquisition instrument types include computer boards, instruments or systems, data loggers or recorders, chart recorders, input modules, output modules, and I/O modules. Computer boards are self-contained printed circuit board with full data acquisition functionality; typically plugs into a back lane or motherboard, or otherwise interfaces directly with a computer bus. Instruments or systems are fully packaged with input and output, user interface, communications capability, etc. They may include integral sensors. Data loggers and data recorders are data acquisition units with instrument functionality with specific capability for data storage. For general purpose or application-specific data acquisition. Chart recorders generate real-time plots, graphs or other visualizations of data. Input modules are devices (module or card) configured to accept input of sensors, timers, switches, amplifiers, transistors, etc. for use in the data acquisition system. Output modules are devices with specific functionality for output of amplified, conditioned, or digitized signal. I/O modules have both input and output functionality. Digital or discrete I/O includes on-off signals used in communication, user interface, or control. Common form factor for data acquisition devices include IC or board mount, circuit board, panel or chassis mount, modular bay or slot system, rack mount, DIN rail, and stand-alone. Common device specifications to consider when searching for data acquisition products include differential analog input channels, digital I/O channels, sampling frequency, resolution and accuracy. Common signal inputs available for data acquisition products include DC voltage, DC current, AC voltage, AC current, frequency, and charge. Sensor inputs include accelerometer, thermocouple, thermistor, RTD, strain with specific capability for data storage. May be for general purpose or application-specific data acquisition. Chart recorders generate real-time plots, graphs or other visualizations of data. Input modules are devices (module or card) configured to accept input of sensors, timers, switches, amplifiers, transistors, etc. for use in the data acquisition system. Output modules are devices with specific functionality for output of amplified, conditioned, or digitized Signal. I/O modules have both input and output functionality. Digital or discrete I/O includes on-off signals used in communication, user interface, or control. Common form factor for data acquisition devices include IC or board mount, circuit board, panel or chassis mount, modular bay or slot system, rack mount, DIN rail, and stand-alone. Common device specifications to consider when searching for data acquisition products include differential analog input channels, digital I/O channels, sampling frequency, resolution and accuracy. Common signal inputs available for data acquisition products include DC voltage, DC current, AC voltage, AC current, frequency, and charge. Sensor inputs include accelerometer, thermocouple, thermistor, RTD, strain gauge or bridge, and LVDT or RVDT. Specialized inputs include encoder, counter or tachometer, timer or clock, and relay or switch. Transducers and excitation are also important to consider when searching for data acquisition. Many products have integral sensors or transducers. These sensors can have voltage or current excitation. Common outputs for data acquisition products include voltage output, current output, frequency output, timer or counter output, relay output, and resistance or potentiometer output. Considering the user interfaces available is important when searching for data acquisition products. User interfaces available include no display, front panel and display, touch screens, hand-held or remote programmers, and computer programmable. Host connection choices include direct backplane interface, RS232, RS422, ST485, USB, research 1394, GPIB, SCSI, TTL, parallel, Ethernet, modem, and radio or telemetry. The transmission rate of data is important to consider. Many products are web enabled for web addressing. Common applications for data acquisition products include general lab or industrial, environmental, vehicular, marine, aerospace or military, seismic or geotechnical, weather or meteorology, and medical or biomedical. Additional specifications to consider when searching for data acquisition products include application software, memory and storage, network specifications, filter specifications, amplifier specifications, and environmental parameters.

Since their first introduction in EEC, automotive electronic sensor application opportunities have grown significantly. Today's high-volume applications include manifold absolute pressure (MAP) sensors, airbag accelerometers, tire-pressure monitors, and yaw-rate sensors. Many vehicle manufacturers and first tier automotive system suppliers are working earnestly on myriad new sensor-based applications for next generation vehicles. Of major interest are sensors for alternate fuel vehicles, such as diesel, hybrid, electric, natural gas, and hydrogen.

Automotive engineers are challenged by a multitude of stringent requirements. For example, automotive sensors typically must have combined/total error less than 3 % over their entire range of operating temperature and measured change, including all measurement errors due to nonlinearity,

3. System Description

Rack And Pinion Arrangement:-

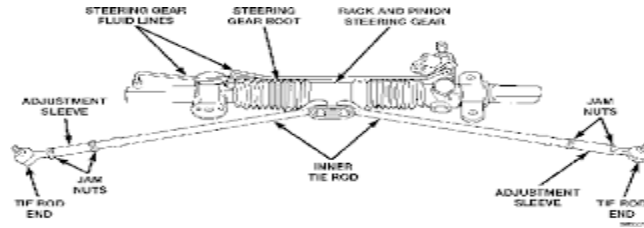

Fig. 1

Rack-and-pinion steering is quickly becoming the most common type of steering on cars, small trucks and SUVs. It is actually a pretty simple mechanism. A rack-and-pinion gear set is enclosed in a metal tube, with each end of the rack protruding from the tube. A rod, called a tie rod, connects to each end of the rack.

The pinion gear is attached to the steering shaft. When you turn the steering wheel, the gear spins, moving the rack. The tie rod at each end of the rack connects to the steering arm on the spindle results in the wheels of the car turning 20 degrees, and then the steering ratio is 360 divided by 20, or 18:1. A higher ratio means that you have to turn the steering wheel more to get the wheels to turn a given distance. However, less effort is required because of the higher gear ratio.

Generally, lighter, sportier cars have lower steering ratios than larger cars and trucks. The lower ratio gives the steering a quicker response -- you don't have to turn the steering wheel as much to get the wheels to turn a given distance -- which is a desirable trait in sports cars. These smaller cars are light enough that even with the lower ratio, the effort required to turn the steering wheel is not excessive. Some cars have variable-ratio steering, which uses a rack-and-pinion gear set that has a different tooth pitch (number of teeth per inch) in the centre than it has on the outside. This makes the car respond quickly when starting a turn (the rack is near the centre), and also reduces effort near the wheel's turning limits.

The rack-and-pinion gear set does two things:

- It converts the rotational motion of the steering wheel into the linear motion needed to turn the wheels.
- It provides a gear reduction, making it easier to turn the wheels.

On most cars, it takes three to four complete revolutions of the steering wheel to make the wheels turn from lock to lock (from far left to far right).

MPU6050

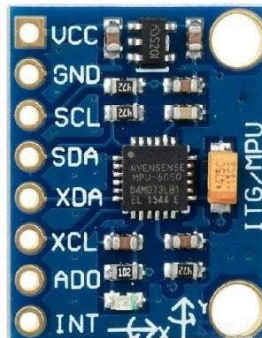

Fig. 2

MPU6050 Features

- MEMS 3-axis accelerometer and 3-axis gyroscope values combined
- Power Supply: 3-5V
- Communication : I2C protocol
- Built-in 16-bit ADC provides high accuracy
- Built-in DMP provides high computational power
- Can be used to interface with other IIC devices like magnetometer
- Configurable IIC Address

The MPU6050 is a Micro Electro-Mechanical Systems (MEMS) which consists of a 3-axis Accelerometer and 3-axis Gyroscope inside it. This helps us to measure acceleration, velocity, orientation, displacement and many other motion related parameter of a system or object. This module also has a (DMP) Digital Motion Processor inside it which is powerful enough to perform complex calculation and thus free up the work for Microcontroller.

The module also have two auxiliary pins which can be used to interface external IIC modules like an magnetometer,however it is optional. Since the IIC address of the module is configurable more than one MPU6050 sensor can be interfaced to a Microcontroller using the AD0 pin. This module also has well documented and revised libraries available hence it's very easy to use with famous platforms like Arduino. So if you are looking for a sensor to control motion for your RC Car, Drone, and Self balancing Robot, Humanoid, Biped or something like that then this sensor might be the right choice for you.

DC motor:-

A dc motor is any of a class of rotary electrical machines that converts direct current electrical energy into mechanical energy. The most common types rely on the forces produced by magnetic fields. Nearly all types of DC motors have some internal mechanism, either electromechanical or electronic; to periodically change the direction of current flow in part of the motor.

DC motors were the first type widely used, since they could be powered from existing direct-current lighting power distribution systems. A DC motor's speed can be controlled over a wide range, using either a variable supply voltage or by changing the strength of current in its field windings. Small DC motors are used in tools, toys, and appliances. The universal motor can operate on direct current but is a lightweight brushed motor used for portable power tools and appliances. Larger DC motors are used in propulsion of electric vehicles, elevator and hoists, or in drives for steel rolling mills. The advent of power electronics has made replacement of DC motors with motors possible in many applications.



Fig. 3

There are three types of electrical connections between the stator and rotor possible for DC electric motors: series, shunt/parallel and compound (various blends of series and shunt/parallel) and each has unique speed/torque characteristics appropriate for different loading torque profiles/signatures.

1. Series connection

A series DC motor connects the armature and field windings in series with a common D.C. power source. The motor speed varies as a non-linear function of load torque and armature current; current is common to both the stator and rotor yielding current squared (I^2) behavior. A series motor has very high starting torque and is commonly used for starting high inertia loads, such as trains, elevators or hoists. This speed/torque characteristic is useful in applications such as dragline excavators, where the digging tool moves rapidly when unloaded but slowly when carrying a heavy load.

A series motor should never be started at no load. With no mechanical load on the series motor, the current is low, the counter-Electro motive force produced by the field winding is weak, and so the armature must turn faster to produce sufficient counter-EMF to balance the supply voltage. The motor can be damaged by over speed. This is called a runaway condition.

Series motors called universal motors can be used on alternating current. Since the armature voltage and the field direction reverse at the same time, torque continues to be produced in the same direction. However they run at a lower speed with lower torque on AC supply when compared to DC due to reactance voltage drop in AC which is not present in DC.[3]Since the speed is not related to the line frequency, universal motors can develop higher-than- synchronous speeds, making them lighter than induction motors of the same rated mechanical output.

This is a valuable characteristic for hand-held power tools. Universal motors for commercial utility are usually of small capacity, not more than about 1 kW output. However, much larger universal motors were used for electric locomotives, fed by special low- frequency traction power networks to avoid problems with commutation under heavy and varying loads.

2. Shunt connection

A shunt DC motor connects the armature and field windings in parallel or shunt with a common D.C. power source. This type of motor has good speed regulation even as the load varies, but does not have the starting torque of a series DC motor.[4] It is typically used for industrial, adjustable speed applications, such as machine tools, winding/unwinding machines and tensioners.

3. Compound connection

A compound DC motor connects the armature and fields windings in a shunt and a series combination to give it characteristics of both a shunt and a series DC motor. This motor is used when both a high starting torque and good speed regulation is needed. The motor can be connected in two arrangements: cumulatively or differentially. Cumulative compound motors connect the series field to aid the shunt field, which provides higher starting torque but less speed regulation. Differential compound DC motors have good speed regulation and are typically operated at constant speed.

Motor controller:-

The L298N is an integrated monolithic circuit in a 15- lead Multi-watt and PowerSO20 packages. It is a high voltage, high current dual full-bridge driver de-signed to accept standard TTL logic level sand drive inductive loads such as relays, solenoids, DC and stepping motors. Two enable inputs are provided to enable or disable the device independently of the in-put signals .The emitters of the lower transistors of each bridge are connected together rand the corresponding

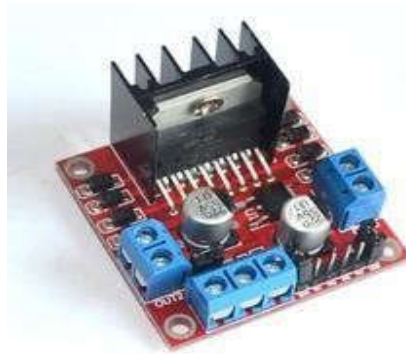
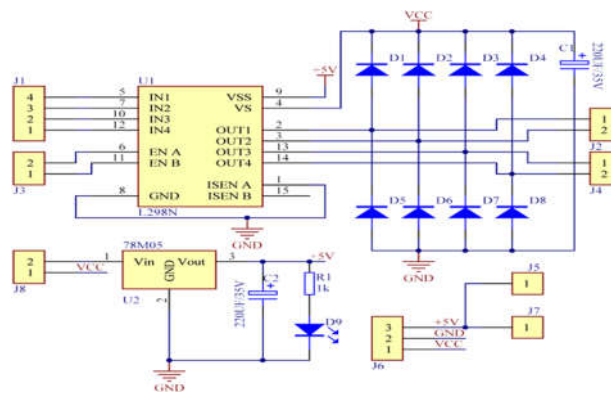

Fig. 4

external terminal can be used for the connection of an external sensing resistor. An additional Supply input is provided so that the logic works at a lower voltage.

Its schematic diagram is as shown in figure :-



Drive voltage: 5-35V; logic voltage: 5V PCB size: 4.2 x 4.2 cm

Specifications:-

- logic voltage - 5V
- motor drive voltage - 5~35V DC
- maximum power 25W

Arduino Micro-Controller:-

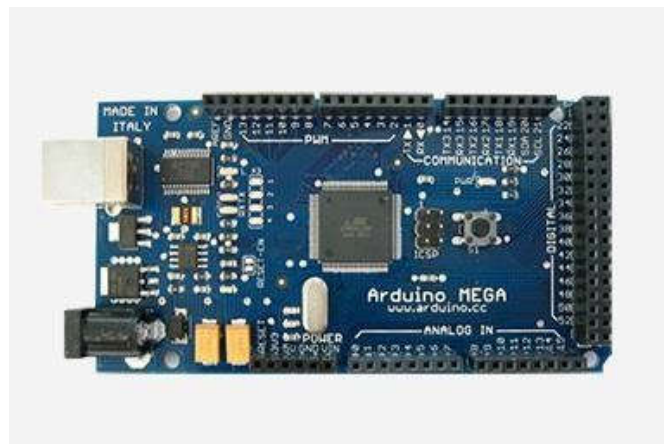

Fig. 6

The Arduino Mega 2560 is a microcontroller board based on the ATmega2560. It has 54 digital input/output pins (of which 15 can be used as PWM outputs), 16 analog inputs, 4 UARTs (hardware serial ports), a 16 MHz crystal oscillator, a USB connection, a power jack, an ICSP header, and a reset button. It contains everything needed to support the microcontroller; simply connect it to a computer with a USB cable or power it with a AC-to-DC adapter or battery to get started. The Mega 2560 board is compatible with most shields designed for the Uno and the former boards Duemilanove or Diecimila.

Specifications: Microcontroller: ATmega2560 Operating Voltage 5V

Input Voltage (recommended) 7-12V

Input Voltage (limits) 6-20V

Digital I/O Pins 54 (of which 14 provide PWM output) Analog Input Pins 16

DC Current per I/O Pin 40 mA DC Current for 3.3V Pin 50 mA

Flash Memory 256 KB of which 8 KB used by bootloader SRAM 8 KB

EEPROM 4 KB

Clock Speed 16 MHz

The Arduino Mega2560 can be powered via the USB connection or with an external power supply. The power source is selected automatically. External (non-USB) power can come either from an AC-to-DC adapter (wall-wart) or battery. The adapter can be connected by plugging a 2.1mm centre-positive plug into the board's power jack. Leads from a battery can be inserted in the Gnd and Vin pin headers of the POWER connector. The board can operate on an external supply of 6 to 20 volts. If supplied with less than 7V, however, the 5V pin may supply less than five volts and the board may be unstable. If using more than 12V, the voltage regulator may overheat and damage the board. The recommended range is 7 to 12 volts. The Mega2560 differs from all preceding boards in that it does not use the FTDI USB-to-serial driver chip. Instead, it features the Atmega8U2 programmed as a USB-to-serial converter.

Battery:



Fig. 7

An electric battery is a device consisting of one or more electrochemical cells with external connections provided to power electrical devices such as flashlights, smartphones, and electric cars. When a battery is supplying electric power, its positive terminal is the cathode and its negative terminal is the anode. The terminal marked negative is the source of electrons that will flow through an external electric circuit to the positive terminal. When a battery is connected to an external electric load, a redox reaction converts high-energy reactants to lower-energy products, and the free-energy difference is delivered to the external circuit as electrical energy. Historically the term "battery" specifically referred to a device composed of multiple cells, however the usage has evolved to include devices composed of a single cell.

Primary (single-use or "disposable") batteries are used once and discarded; the electrode materials are irreversibly changed during discharge. Common examples are the alkaline battery used for flashlights and a multitude of portable electronic devices. Secondary (rechargeable) batteries can be discharged and recharged multiple times using an applied electric current; the original composition of the electrodes can be restored by reverse current. Examples include the lead- acid batteries used in vehicles and lithium-ion batteries used for portable electronics such as laptops and smartphones.

Specifications:

Voltage 12V

Capacity 7.5Ah

Connection 4.8mm Blade

Dimensions 65 x 94 x 151mm

Weight 2.17kg

4. Block diagram

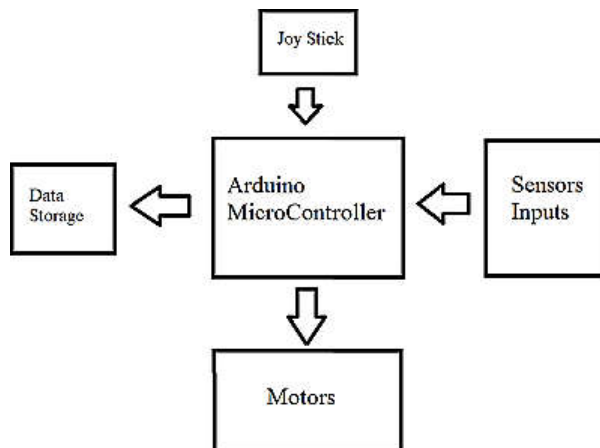

5. Working

The model is a four wheel vehicle. The front wheels are two caster wheels connected to the steering system. The rear wheels are simple bot wheels connected to motors. The front steering mechanism is a rack and pinion arrangement. The rear wheels are directly DC motor powered. The pinion is connected to a vertically mounted 100 rpm 12V DC geared motor. The rack is suspended directly on the caster wheels via two fibre plates. The rear motors are 500 rpm 12V DC geared motors. Two different L298N motor drivers are used. One driver entirely for steering pinion movement. Other driver to drive the two DC motors. The motor driver controls the speed and direction of the motors. The motor driver takes input from the micro-controller for PWM and direction inputs. The motor driver is separately powered with a 12V DC supply to drive the motors. The motor driver is a dual channel driver so it can simultaneously drive two DC motors. The control input for the movement is given through joystick. It is a potentiometer based joystick and can give both horizontal and vertical input. It has to be powered with a 5V supply. The joystick gives values with respect to ground. The analog values are taken from joystick. The microcontroller used is a atmega 2560 Arduino/genuine mega development board. The micro-controller has analog ports and Digital Ports for the operation. It is powered to a 12V/5V adapter supply or through a serial port connected to computer via usb cable.

The analog values from the joystick in vertical and horizontal movements is converted to digital values in a range of 0- 1023. It uses a 10 bit internal ADC for this purpose. The working of the motors is controlled via software loops according to the joystick values. The pinion motor is based upon the horizontal movements from the joystick which eventually controls the steering mechanism. When the motor rotates to and fro the steering mechanism works to rotate the front wheels left and right. Therefore joystick controls the front wheel angle. The vertical movements of the joystick are again given to analog ports. The software loops control the speed and direction of motor according to the vertical movements of the joystick. The motor speed can be changed through software. Also the direction is controlled by the controller. Now the joystick can be used to fully control the position of the vehicle. The orientation and acceleration values are given by a MPU 6050. It is a MEMS accelerometer and gyroscope embedded inside a small chip. It uses I2C communications to give the sensor values. Two pins from the analog ports are used as a serial clock and serial data for the I2C communications. The I2C communications gives six values from the sensor. Three values of three axis accelerometer and three values of gyroscope orientation. These values are displayed on the serial monitor along with the joystick values. So the input for the system is constantly visible to the operator when the micro-controller is connected to the computer. A single axis gyroscope value is taken in account for the tilt angle. When the tilt angle crosses 45 degrees the steering system loop factor is reduced. Further limiting the pinion motor rotation. This enables to limit the steering angle when the vehicle is at or beyond a tilt angle. The vehicle is further saved from a roll over in a critical angle situation. Further helping the operator to safely control the vehicle in such a situation.

6. Advantages & Disadvantages

Advantages

- It is a scalable model.
- This can be used large scale applications.
- This application can be help to reduce an accidents causes by traction of vehicle.
- Gives a warning before danger situation.

.Disadvantages

- The system is not tested with a working suspension set up.
- Unlike normal vehicles the rear wheels are separately powered instead transmission system.
- The full control is on joystick which is unconventional.

7. Scope of Project

- Proximity Sensor, Wheel Speed Sensor, Damper Travel Sensors, Inertial Measurement have to be added in the system.
- A Suspension setup has to be applied to the system.
- A bluetooth control model can be added for wireless control.
- A lithium polymer battery and BLDC motor can be added for longer battery life, light weight and high power output.

8. Conclusion

- The Model is a representation of an high CG, Heavy Weight, 4 Wheel Vehicle.
- Model can be used to demonstrate multiple dynamic scenarios.
- Faults can be easily created in the system, both software and hardware based.

REFERENCES

-
- [1] Chen Peijiang, Jiang Xuehua, "Design and Implementation of Remote monitoring system based on GSM," vol.42, pp.167-175. 2008.
 - [2] V.Ramya, B. Palaniappan, K. Karthick, "Embedded Controller for Vehicle In-Front Obstacle Detection and Cabin Safety Alert System", (IJCSIT) Vol 4, No 2, April 2012
 - [3] Asaad M. J. Al-Hindawi, Ibraheem Talib, "Experimentally Evaluation of GPS/GSM Based System Design", Journal of Electronic Systems Volume 2 Number 2 June 2012
 - [4] Kumar Yelamarthi, Daniel Haas, "RFID and GPS integrated navigation system for the visually impaired", 53rd IEEE International Midwest Symposium on Circuits and Systems, 2010.
 - [5] Farooq, U.M. Amar, M. U. Asad, A. Iqbal, "GPS-GSM integration for enhancing public transportation management services", International Conference on Computer Engineering and Applications, Volume 2, pp: 142-147, March 2010.
 - [6] Sumit S. Dukare, Dattatray A. Patil, Kantilal P. Rane, "Vehicle Tracking, Monitoring and Alerting System: A Review", International Journal of Computer Applications (0975-8887) Volume 119 -No.10, June 2015
 - [7] Saravanan Kannan, Arunkumar Thangavelu, Ramesh Babu Kalivaradhan, "An Intelligent Driver Assistance System (I-DAS) for Vehicle Safety Modelling using Ontology Approach", International Journal Of UbiComp (IJU), Vol.1, No.3, July 2010
 - [8] SIMCOM SIM300 AT Commands Set/Hardware interface description